



MG75HF12TLC1

IGBT Modules

V_{CES}	1200V
I_c	75A

Applications

Inverter for motor drive
AC and DC servo drive amplifier
UPS (Uninterruptible Power Supplies)
Soft switching welding machine

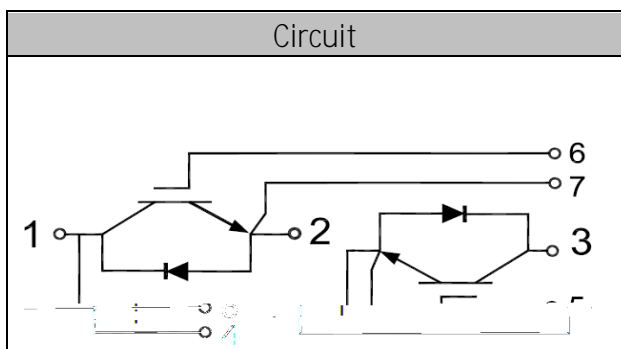

Features

Low $V_{ce(sat)}$ with Trench technology
 $V_{ce(sat)}$ with positive temperature coefficient
High short circuit capability(10us)
Including ultra fast & soft recovery anti-parallel FWD
Low inductance
Maximum junction temperature 175

● IGBT

Absolute Maximum Ratings

Parameter	Symbol	Conditions	Value	Unit
Collector-Emitter Voltage	V_{CES}	$V_{GE}=0V, I_c = 1mA, T_{vj}=25$	1200	V
Continuous Collector Current	I_c	$T_c=100$	75	A
Repetitive Peak Collector Current	I_{CRM}	$t_p=1ms$	150	A
Gate-Emitter Voltage	V_{GES}	$T_{vj}=25$	20	V
Total Power Dissipation	P_{lot}	$T_c=25$ $T_{vjmax}=175$	530	W

MG75HF12TLC1

Characteristic values

Parameter	Symbol	Conditions	Value			Unit	
			Min.	Typ.	Max.		
Gate-emitter Threshold Voltage	$V_{GE(th)}$	$V_{GE}=V_{CE}, I_C=3mA, T_{vj}=25$	5.0	6.2	7.0	V	
Collector-Emitter Cut-off Current	I_{CES}	$V_{CE}=1200V, V_{GE}=0V, T_{vj}=25$			1.0	mA	
Collector-Emitter Saturation Voltage	$V_{CE(sat)}$	$I_C=75A, V_{GE}=15V, T_{vj}=25$		1.85		V	
		$I_C=75A, V_{GE}=15V, T_{vj}=125$		2.05			
Input Capacitance	C_{ies}	$V_{CE}=25V, V_{GE}=0V,$ $f=1MHz, T_{vj}=25$		5.52		nF	
Reverse Transfer Capacitance	C_{res}			0.26		nF	
Gate-Emitter leakage current	I_{GES}	$V_{CE}=0V, V_{GE}=20V, T_{vj}=25$			400	nA	
Turn-on Delay Time	$t_{d(on)}$	$I_C=75A$ $V_{CE}=600V$ $V_{GE}=\pm 15V$ $R_G=10$ $T_{vj}=25$		305		ns	
Rise Time	t_r			67		ns	
Turn-off Delay Time	$t_{d(off)}$			328		ns	
Fall Time	t_f			187		ns	
Energy Dissipation During Turn-on Time	E_{on}			6.7		mJ	
Energy Dissipation During Turn-off Time	E_{off}			4.3		mJ	
Turn-on Delay Time	$t_{d(on)}$		$I_C=75A$ $V_{CE}=600V$ $V_{GE}=\pm 15V$ $R_G=10$ $T_{vj}=125$		311		ns
Rise Time	t_r				70		ns
Turn-off Delay Time	$t_{d(off)}$			347		ns	
Fall Time	t_f			337		ns	
Energy Dissipation During Turn-on Time	E_{on}			9.7		mJ	
Energy Dissipation During Turn-off Time	E_{off}			7.0		mJ	
SC Data	I_{sc}	$T_p=10\mu s, V_{GE}=15V,$ $T_{vj}=150, V_{cc}=600V,$ $V_{CEM}=1200V$			420		A



MG75HF12TLC1

● Diode

Absolute Maximum Ratings

Parameter	Symbol	Conditions	Value	Unit
Repetitive Peak Reverse Voltage	V_{RRM}	$T_{vj}=25$	1200	V
Continuous DC Forward Current	I_F		75	A
Repetitive Peak Forward Current	I_{FRM}	$t_p=1ms$	150	A

Characteristic values

Parameter	Symbol	Conditions	Value			Unit
			Min.	Typ.	Max.	
Forward Voltage	V_F	$I_F=75A, T_{vj}=25$		2.10		V
		$I_F=75A, T_{vj}=125$		2.00		
Recovered Charge	Q_{rr}	$I_F=75A$		4.8		μC
Peak Reverse Recovery Current	I_{rr}	$V_R=600V$ $-di_F/dt=1200A/\mu s$		60		A
Reverse Recovery Energy	E_{rec}	$T_{vj}=25$		3.8		mJ
Recovered Charge	Q_{rr}	$I_F=75A$		10.2		μC
Peak Reverse Recovery Current	I_{rr}	$V_R=600V$ $-di_F/dt=1200A/\mu s$		77		A
Reverse Recovery Energy	E_{rec}	$T_{vj}=125$		5.7		mJ



MG75HF12TLC1

● Module Characteristics

T_c=25°C unless otherwise specified

Parameter	Symbol	Conditions	Value			Unit
			Min.	Typ.	Max.	
Isolation voltage	V _{isol}	t=1min,f=50Hz	2500			V
Maximum Junction Temperature	T _{jmax}				175	
Operating Junction Temperature	T _{vj op}		-40		150	
Storage Temperature	T _{stg}		-40		125	
Thermal Resistance Junction-to Case	R _{jc}	per IGBT			0.26	K/W
		per Diode			0.42	
Thermal Resistance Case-to Sink	R _{cs}	Conductive grease applied		0.05		K/W
Module Electrodes Torque	M _t	Recommended(M5)	2.5		5.0	N·m
Module-to-Sink Torque	M _s	Recommended(M6)	3.0		5.0	N·m
Weight of Module	G			150		g



MG75HF12TLC1

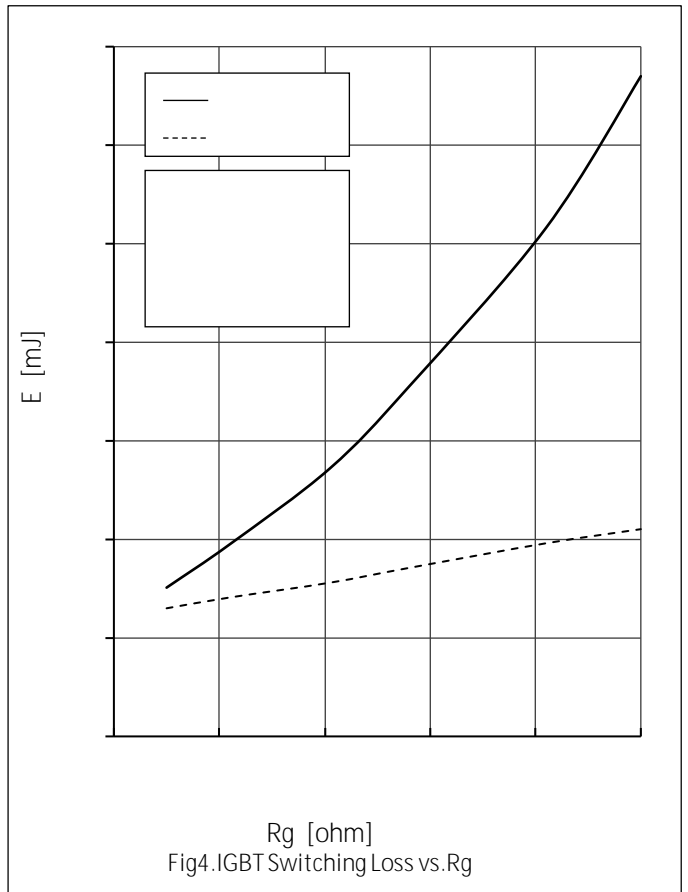
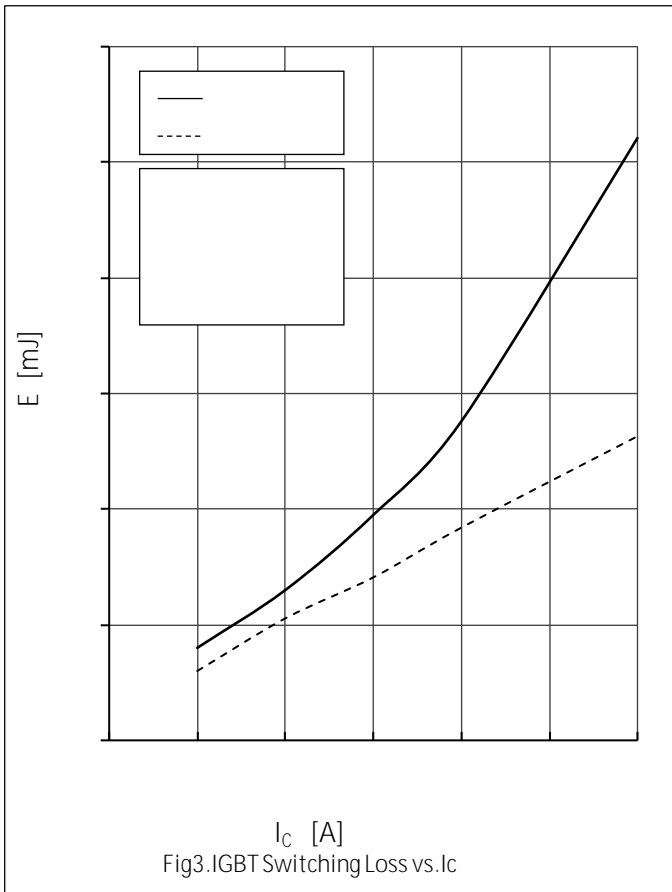
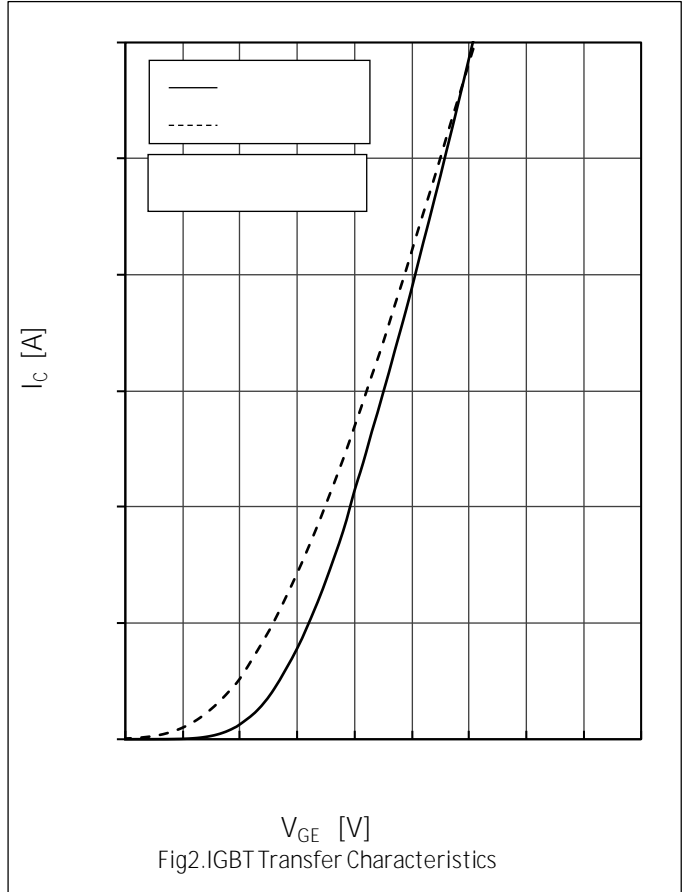
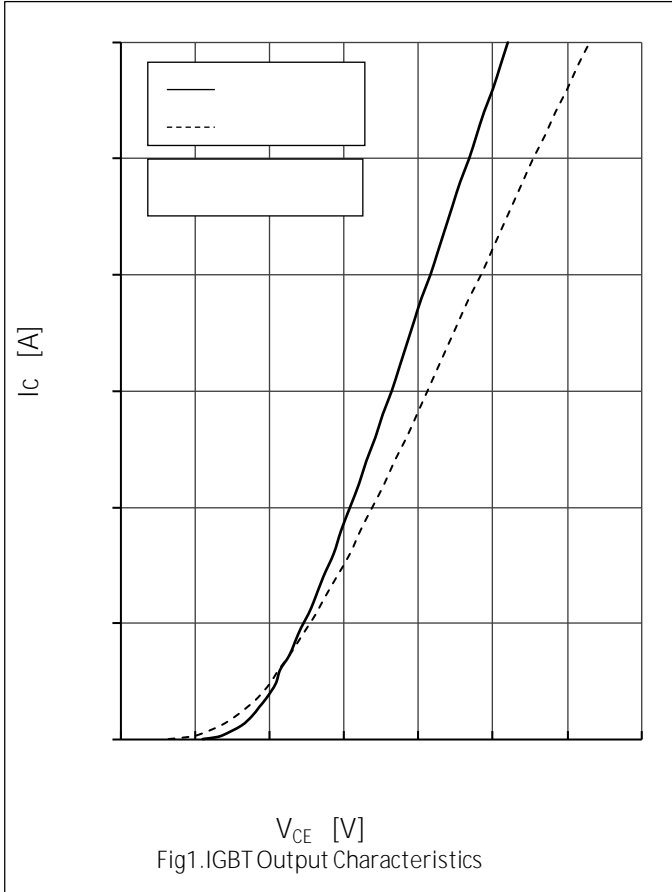



MG75HF12TLC1

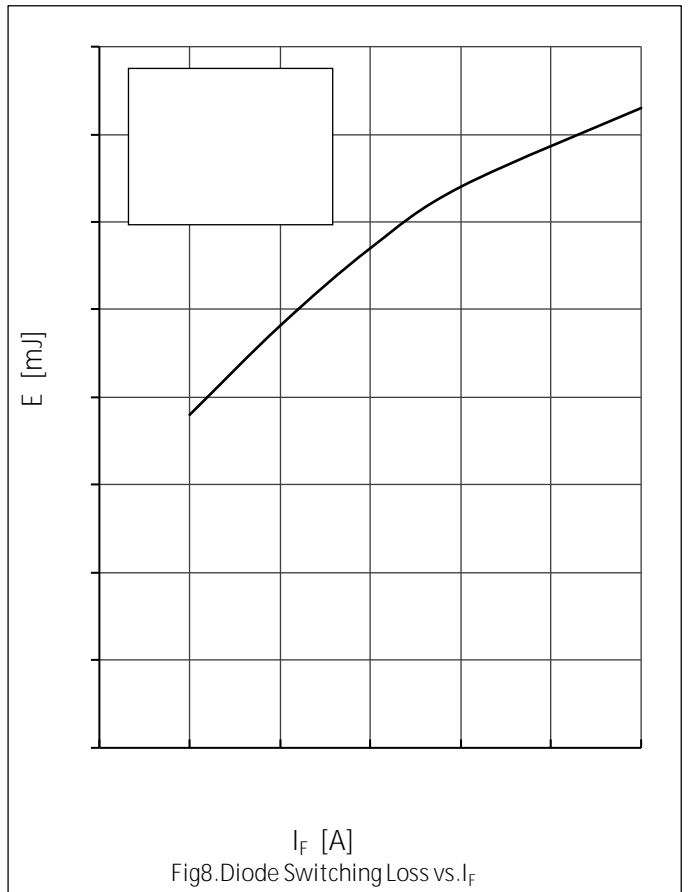
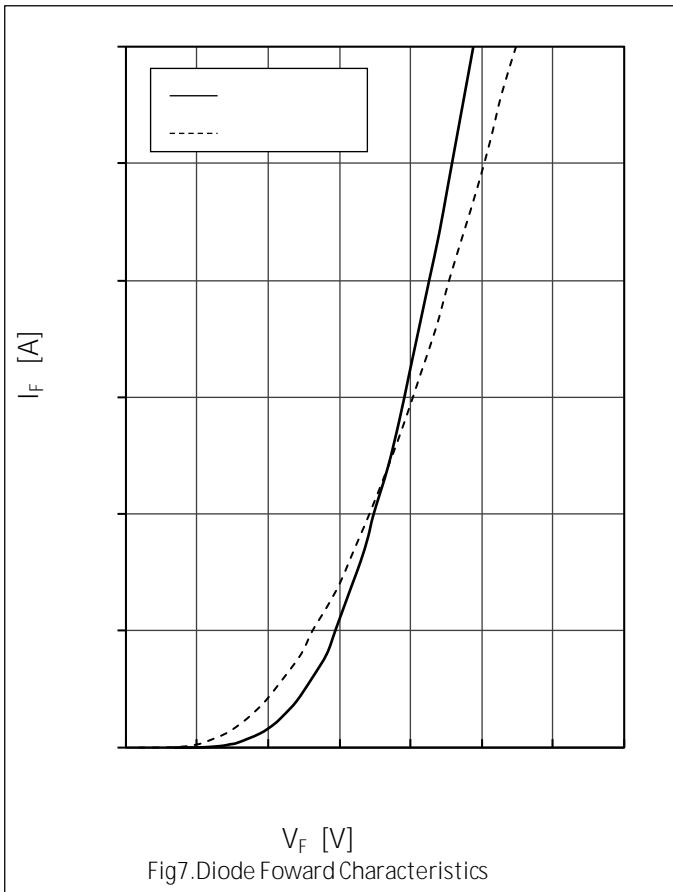
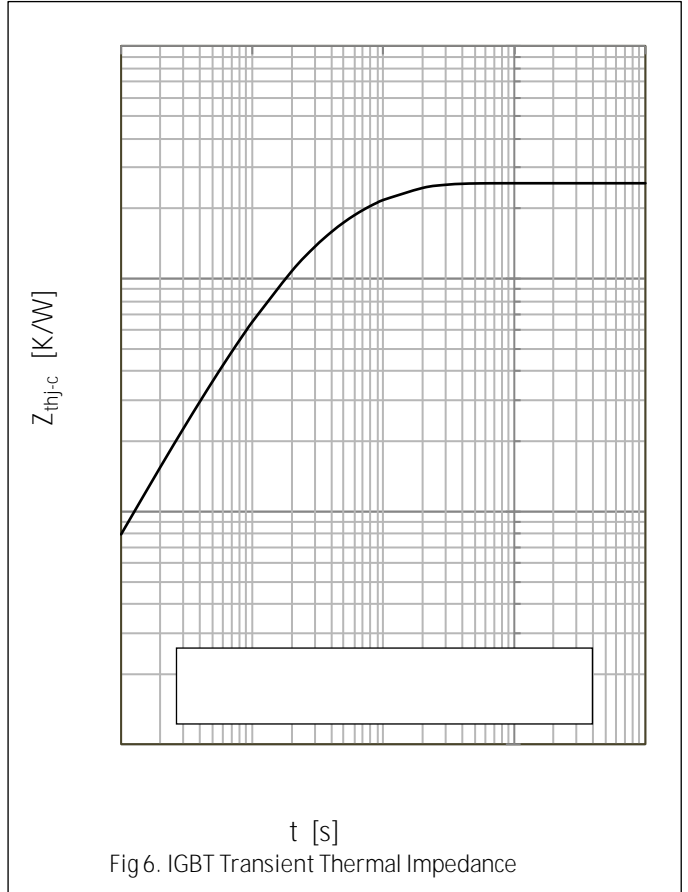
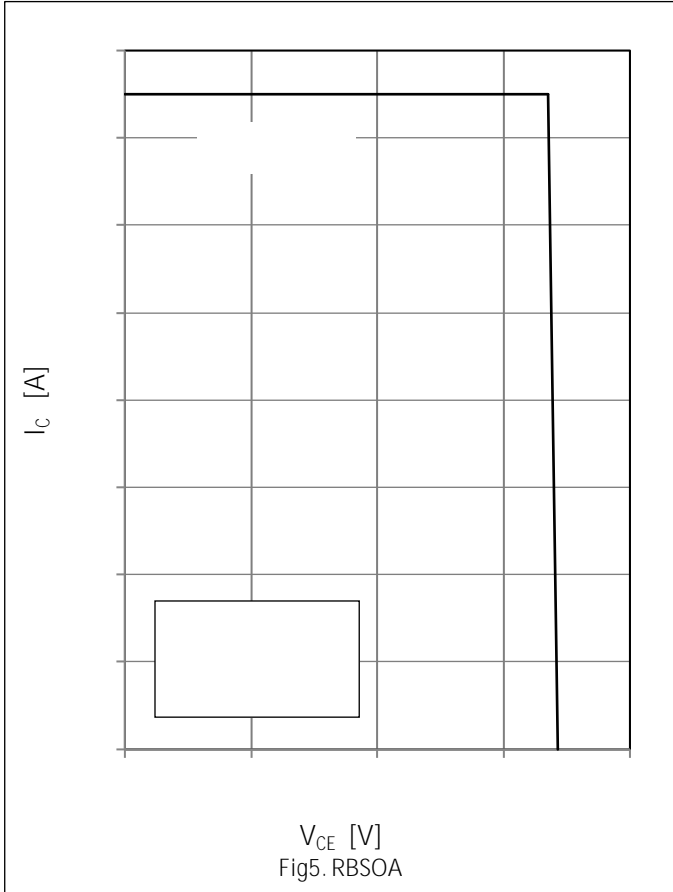



MG75HF12TLC1

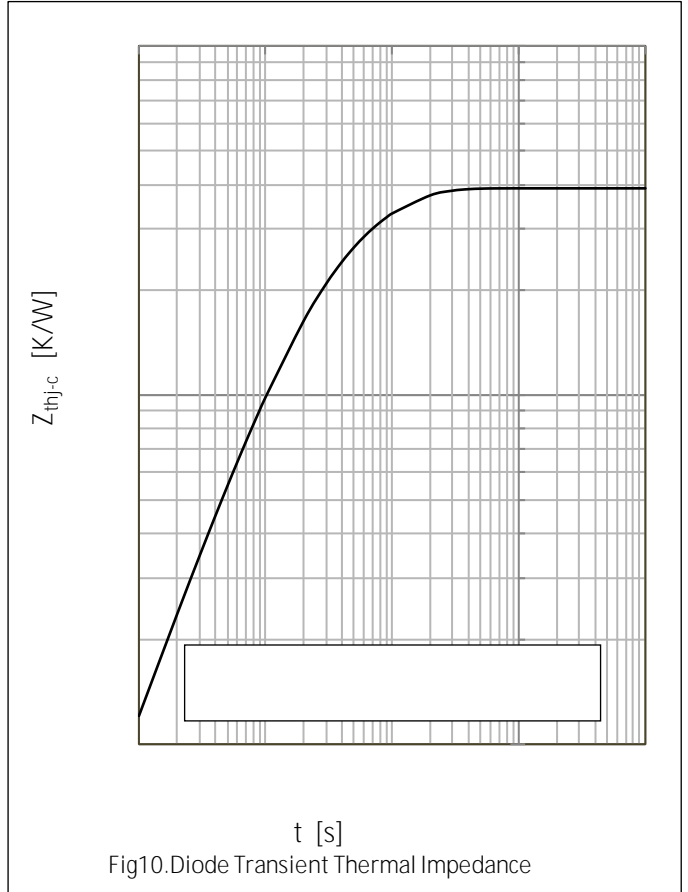
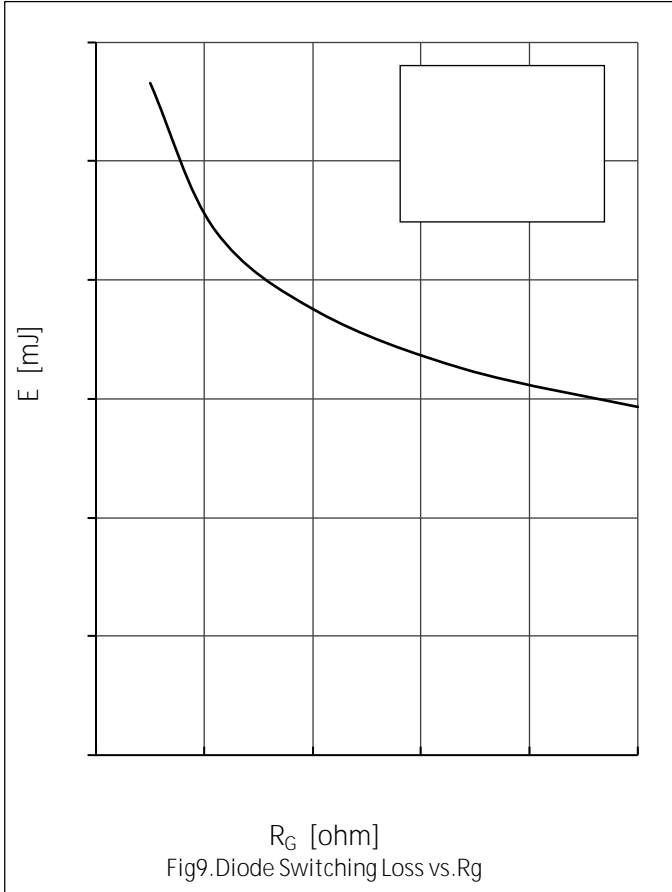



MG75HF12TLC1

● Circuit Diagram

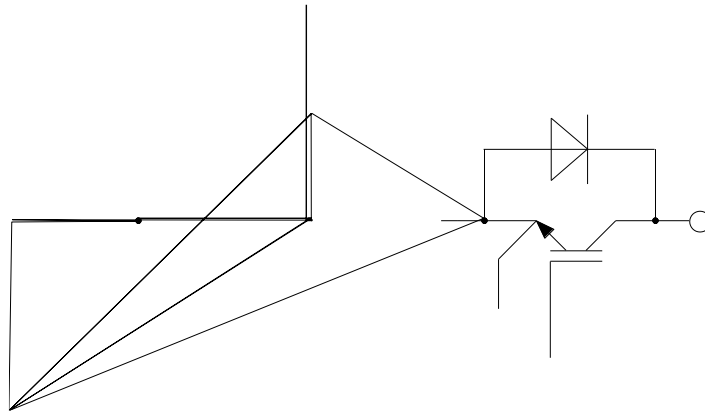

● Package Outline Information

Dimensions in Millimeters

