



深圳市弗瑞鑫电子有限公司

规格承认书

—
————
————

| | | | |
|--|--|--|--|
| | | | |
| | | | |

| | |
|---------|--|
| prepare | |
| | |
| check | |
| | |
| approve | |
| | |



TRX电容一级代理商

深圳市弗瑞鑫电子有限公司

Add:深圳市宝安区西乡大道302号金源商务大厦B座3楼

Tel:0755-29563634

Fax:0755-27447020

| | | | | |
|---|---|--|-------|--|
|  TRX 专注电容器廿年 | SMD Y SMD Y1 a.c. ceramic capacitors | | | |
| | /Number | | /Date | |
| | /Edition | | /Page | |

| | | | |
|---|---|--|-------|
|  <p>TRX 专注电容器廿年</p> | SMD Y SMD Y1 a.c. ceramic capacitors | | |
| | /Number | | /Date |
| | /Edition | | /Page |

1. /Product Name

T M Y1 101 K
 ① ② ③ ④ ⑤

| | | |
|---|--|--|
| | | |
| ① | | |
| ② | | |
| ③ | | |
| ④ | | |
| ⑤ | | |

2. /Product marking

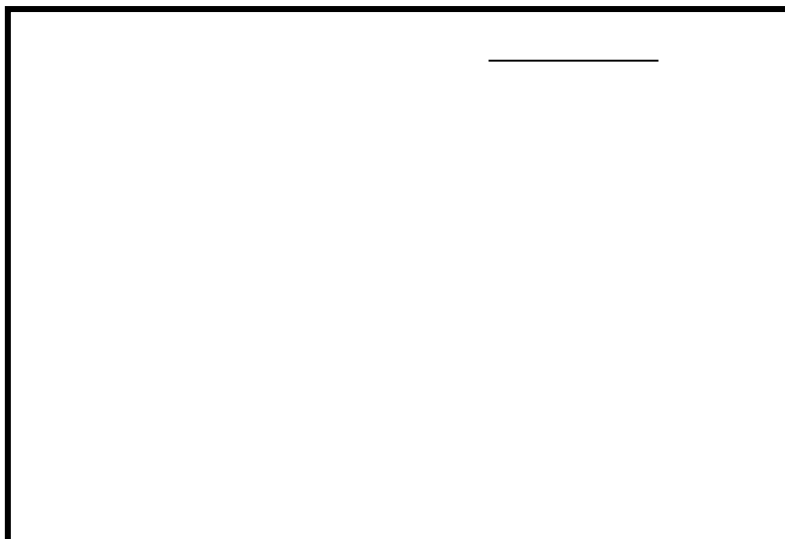

4. /Certificates

| certificates | | | |
|--------------|--|--|--|
| | | | |
| | | | |
| | | | |
| | | | |
| | | | |

5. / Product structure

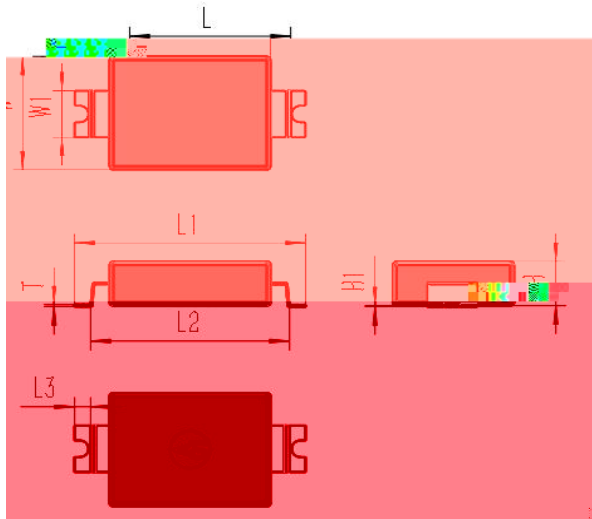

| | | | |
|--|--|--|--|
| | | | |
| | | | |
| | | | |
| | | | |
| | | | |

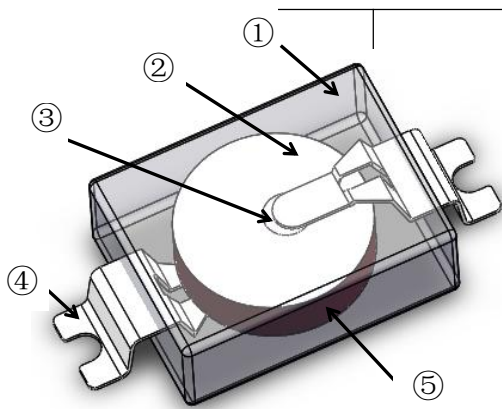

| | | |
|-----|--|--|
| | | |
| | | |
| | | |
| | | |
| | | |
| (4) | | |
| (5) | | |

| | | | |
|---|---|--|-------|
|  | SMD Y SMD Y1 a.c. ceramic capacitors | | |
| | /Number | | /Date |
| | /Edition | | /Page |

/

°
°C
°
°
°

/

7. / Performance and test methods

| | | | | |
|---|---|--|-------|--|
|  TRX 专注电容器廿年 | SMD Y SMD Y1 a.c. ceramic capacitors | | | |
| | /Number | | /Date | |
| | /Edition | | /Page | |





SMD Y
SMD Y1 a.c. ceramic capacitors

/Number

/Date

/Edition

/Page

| | | △ | |
|--|--|---|--|
| | | △ | |
| | | △ | |
| | | △ | |
| | | △ | |
| | | | |
| | | | |
| | | | |
| | | △ | |
| | | △ | |
| | | △ | |
| | | △ | |
| | | △ | |
| | | | |
| | | | |

| | | | | |
|---|---|--|-------|--|
|  TRX 专注电容器廿年 | SMD Y SMD Y1 a.c. ceramic capacitors | | | |
| | /Number | | /Date | |
| | /Edition | | /Page | |



| | | | | |
|---|---|--|-------|--|
|  TRX 专注电容器廿年 | SMD Y SMD Y1 a.c. ceramic capacitors | | | |
| | /Number | | /Date | |
| | /Edition | | /Page | |

11. /Prod

| | | | |
|---|---|--|-------|
|  TRX 专注电容器廿年 | SMD Y SMD Y1 a.c. ceramic capacitors | | |
| | /Number | | /Date |
| | /Edition | | /Page |

/inner-packaging

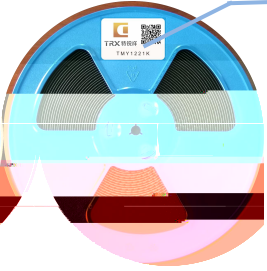

标签



料号

| | |
|--|--|
| | |
| | |
| | |
| | |
| | |
| | |
| | |
| | |
| | |
| | |



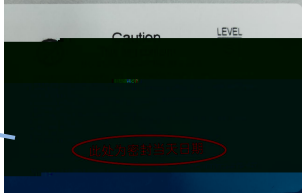

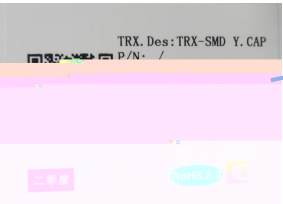

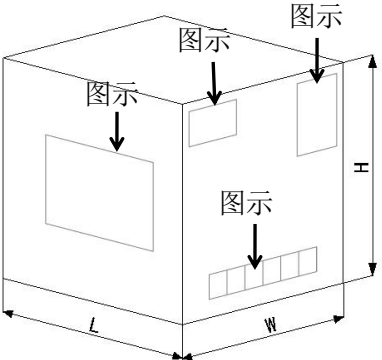

/Outer-packaging







图示 /

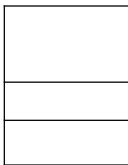

图示 /

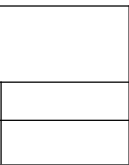

图示 /

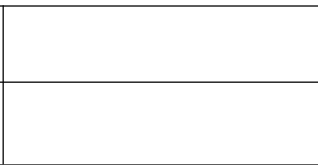

/Package sketch:



/



/





Remark

| | | | |
|---|---|--|-------|
|  | SMD Y SMD Y1 a.c. ceramic capacitors | | |
| | /Number | | /Date |
| | /Edition | | /Page |

12. /Application notes

①

②

③

④

⑤

⑥